



APEX DYNAMICS, INC.

上海聚诺斯自动化科技有限公司 丁蔚

电话/微信: 18717725286

邮箱: dingwei@genius-sh.com

网址: www.genius-sh.com

AD/ADR/ADS Series

Gearboxes
High Precision
High Speed



Stainless

AD/ADR/ADS 系列

產品特點

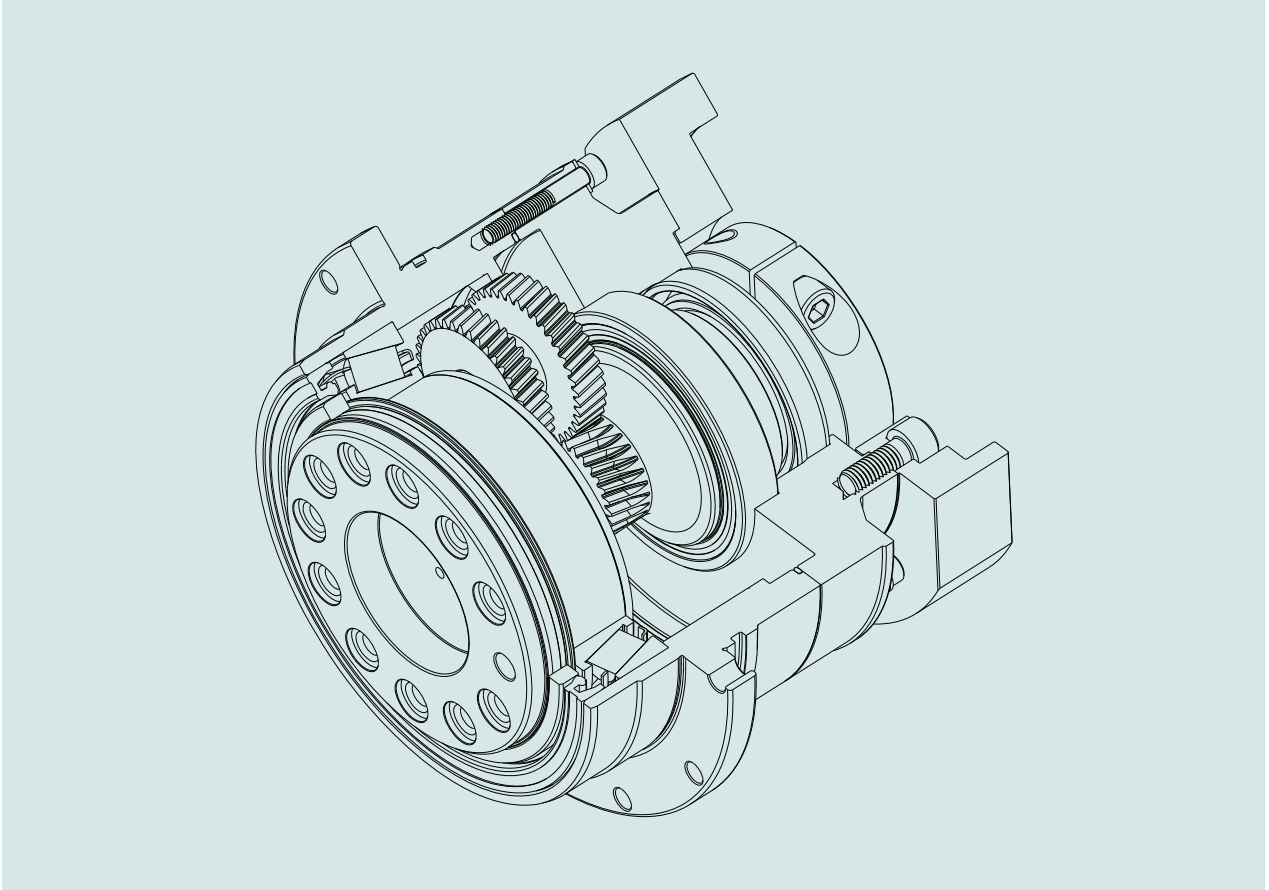

- 利用**3D HeliTopo** 的設計分析技術，分別對螺旋齒面作**齒形及導程修整**，以降低齒輪對嚙入及嚙出的衝擊和噪音，增加齒輪系的使用壽命
- 齒輪材料選用高級的**鉻鉬鈮合金鋼**，加上自設最先進的**離子氮化設備**，將齒輪表面硬度提昇至**900Hv**，中心硬度調質到**30HRc**，以獲得最佳的耐磨耗及耐衝擊韌性。
- 使用合成潤滑油脂，並採**IP65**防護等級的密封設計，潤滑油不洩漏免保養
- **專利的密封系統設計**，採用特殊的油封材質及表面處理技術，降低運轉磨耗與溫升，減少漏油的問題，提供最佳的密封性能。
- 齒輪採用**螺旋齒輪設計**，其齒形嚙合率為一般正齒輪的二倍以上，具有運轉平順、低噪音、高輸出扭矩和低背隙的特性

減速機性能資料

規格	節數	減速比	AD047	AD064	AD090	AD110	AD140	AD200	AD255			
額定輸出力矩 T_{2N}	1	4	19	48	130	270	560	1,100	1,700			
		5	22	60	160	330	650	1,200	2,000			
		7	19	50	140	300	550	1,100	1,800			
		10	14	40	100	230	450	900	1,500			
	Nm	2	20	19	48	130	270	560	1,100	1,700		
			25	22	60	160	330	650	1,200	2,000		
			35	19	50	140	300	550	1,100	1,800		
			40	19	48	130	270	560	1,100	1,700		
		3	50	22	60	160	330	650	1,200	2,000		
			70	19	50	140	300	550	1,100	1,800		
			100	14	40	100	230	450	900	1,500		
			16	19	48	130	270	560	1,100	1,700		
			21	22	60	160	330	650	1,200	2,000		
			31	19	50	140	300	550	1,100	1,800		
			61	19	50	140	300	550	1,100	1,800		
			91	14	40	100	230	450	900	1,500		
			急停扭矩 T_{2NOT}^B	Nm	1,2	3 倍額定輸出力矩						
			額定輸入轉速 n_{1N}	rpm	1,2	4~100	5,000	5,000	4,000	4,000	3,000	3,000
最大輸入轉速 n_{1B}	rpm	1,2	4~100	10,000	10,000	8,000	8,000	6,000	6,000	4,000		
超精密背隙 $P0$	arcmin	1	4~10	-	-	≤1	≤1	≤1	≤1	≤1		
		2	20~100	-	-	≤3	≤3	≤3	≤3	≤3		
精密背隙 $P1$	arcmin	1	4~10	≤3	≤3	≤3	≤3	≤3	≤3	≤3		
		2	20~100	≤5	≤5	≤5	≤5	≤5	≤5	≤5		
標準背隙 $P2$	arcmin	1	4~10	≤5	≤5	≤5	≤5	≤5	≤5	≤5		
		2	20~100	≤7	≤7	≤7	≤7	≤7	≤7	≤7		
扭轉剛性	Nm/arcmin	1,2	4~100	7	13	31	82	151	440	1,006		
最大彎曲力矩 M_{2KB}^C	Nm	1,2	4~100	42.5	125	235	430	1,300	3,064	5,900		
容許軸向力 F_{2aB}^C	N	1,2	4~100	990	1,050	2,850	2,990	10,590	16,660	29,430		
使用壽命 ^D	hr	1,2	4~100	30,000								
效率 η	%	1	4~10	≥97%								
		2	20~100	≥94%								
重量	kg	1	4~10	0.7	1.2	3.0	5.6	11.9	31.6	56.1		
		2	20~100	1.0	1.6	3.7	7.3	15.9	36.9	70.4		
			16~91	1.0	1.4	3.5	6.5	15.5	34.2	67.2		
使用溫度	°C	1,2	4~100	-10°C~90°C								
潤滑				合成潤滑油脂								
防護等級		1,2	4~100	IP65								
安裝方向		1,2	4~100	任意方向								
噪音值 ($n=3000\text{rpm}$, $i=10$, 無負載) ^E	dB(A)	1,2	4~100	≤56	≤58	≤60	≤63	≤65	≤67	≤70		

減速機轉動慣量

規格	節數	減速比	AD047	AD064	AD090	AD110	AD140	AD200	AD255	
轉動慣量 J_1	1	4	0.03	0.14	0.51	2.87	7.54	25.03	58.31	
		5	0.03	0.13	0.47	2.71	7.42	23.29	53.27	
		7	0.03	0.13	0.45	2.62	7.14	22.48	50.97	
		10	0.03	0.13	0.44	2.57	7.03	22.51	50.56	
	kg · cm ²	2	20	0.03	0.03	0.13	0.47	2.71	7.42	23.29
			25	0.03	0.03	0.13	0.47	2.71	7.42	23.29
			35	0.03	0.03	0.13	0.47	2.71	7.42	23.29
			40	0.03	0.03	0.13	0.44	2.57	7.03	22.51
		3	50	0.03	0.03	0.13	0.44	2.57	7.03	22.51
			70	0.03	0.03	0.13	0.44	2.57	7.03	22.51
			100	0.03	0.03	0.13	0.44	2.57	7.03	22.51
			16	0.03	0.03	0.13	0.47	2.71	7.42	23.29
			21	0.03	0.03	0.13	0.47	2.71	7.42	23.29
			31	0.03	0.03	0.13	0.44	2.57	7.03	22.51
			61	0.03	0.03	0.13	0.44	2.57	7.03	22.51
			91	0.03	0.03	0.13	0.44	2.57	7.03	22.51

A. 減速比 ($i=N_n/N_{out}$)

B. 最大加速力矩 $T_{2B} = 60\%$ of T_{2NOT}

C. 輸出轉數 100 rpm 時，作用於輸出軸中心位置。

D. 連續運轉，使用壽命為 10,000 hrs (請洽詢本公司)

E. 噪音值會隨著減速機比數不同而異

AD 系列

尺寸 (單節, 減速比 $i = 4 \sim 10$)

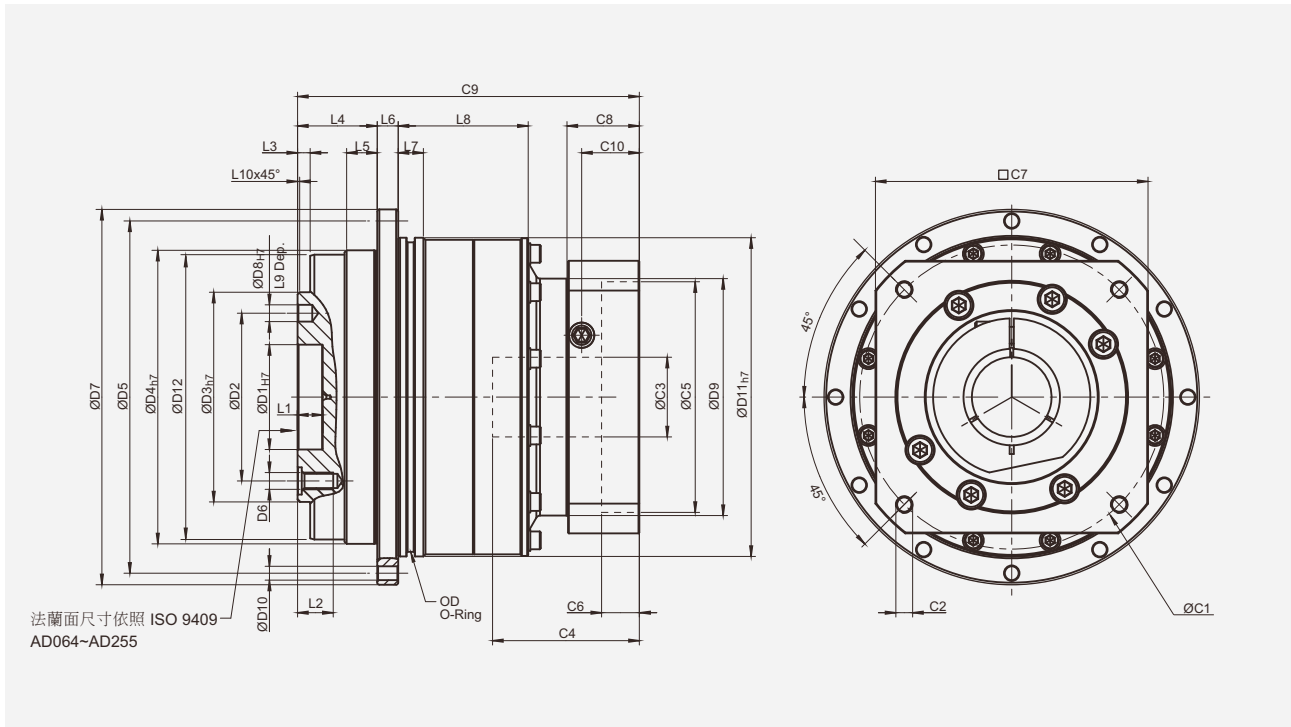

(單位: mm)

尺寸	AD047	AD064	AD090	AD110	AD140	AD200	AD255
D1 _{H7}	12	20	31.5	40	50	80	100
D2	20	31.5	50	63	80	125	140
D3 _{H7}	28	40	63	80	100	160	180
D4 _{H7}	47	64	90	110	140	200	255
D5	67	79	109	135	168	233	280
D6	4 x M3 x 0.5P	7 x M5 x 0.8P	7 x M6 x 1P	11 x M6 x 1P	11 x M8 x 1.25P	11 x M10 x 1.5P	12 x M16 x 2P
D7	72	86	118	145	179	247	300
D8 _{H7}	3	5	6	6	8	10	12
D9	45.5	55	77	90	113	138	175
D10	8 x 3.4	8 x 4.5	8 x 5.5	8 x 5.5	12 x 6.6	12 x 9	16 x 13.5
D11 _{H7}	60	70	95	120	152	212	255
D12	46.2	63.2	89.2	109.2	139.2	199.2	254.2
L1	4	8	12	12	12	16	20
L2	6.5	8	13.5	13.5	17	22.5	30.5
L3	3	3	6	6	6	8	12
L4	19.5	19.5	30	29	38	50	66
L5	7	7	10	10	14.6	15	20
L6	4	4	7	8	10	12	18
L7	5	7.7	8	10	12	15	20
L8	18.5	28.5	27	37	62	69.5	82
L9	4	6	7	7	7	10	10
L10	0.5	0.5	1	1	1	1	1
C1 ¹	46	70	100	130	165	215	235
C2 ¹	M4 x 0.7P	M5 x 0.8P	M6 x 1P	M8 x 1.25P	M10 x 1.5P	M12 x 1.75P	M12 x 1.75P
C3 ¹	≤ 11 / ≤ 12 ²	≤ 14 / ≤ 16 ²	≤ 19 / ≤ 24	≤ 32	≤ 38	≤ 48	≤ 55
C4 ¹	30	34	40	50	60	85	116
C5 ¹	30	50	80	110	130	180	200
C6 ¹	3.5	8	4	5	6	6	6
C7 ¹	48	60	90	115	142	190	220
C8 ¹	19.5	19	17	19.5	22.5	29	63
C9 ¹	70	82.5	99.5	121.5	151	199.5	256.5
C10 ¹	13.25	13.5	10.75	13	15	20.75	53.5
OD	56 x 2	66 x 2	90 x 3	110 x 3	145 x 3	200 x 5	238 x 5

1. C1~C11 是公制標準馬達連接板之尺寸, 請上網點選「減速機選用」找出正確之尺寸。

2. AE047 5, 10 減速比提供 C3 ≤ 12 可選; AE064 5, 10 減速比提供 C3 ≤ 16 可選。

尺寸 (雙節, 減速比 $i = 20 \sim 100$)

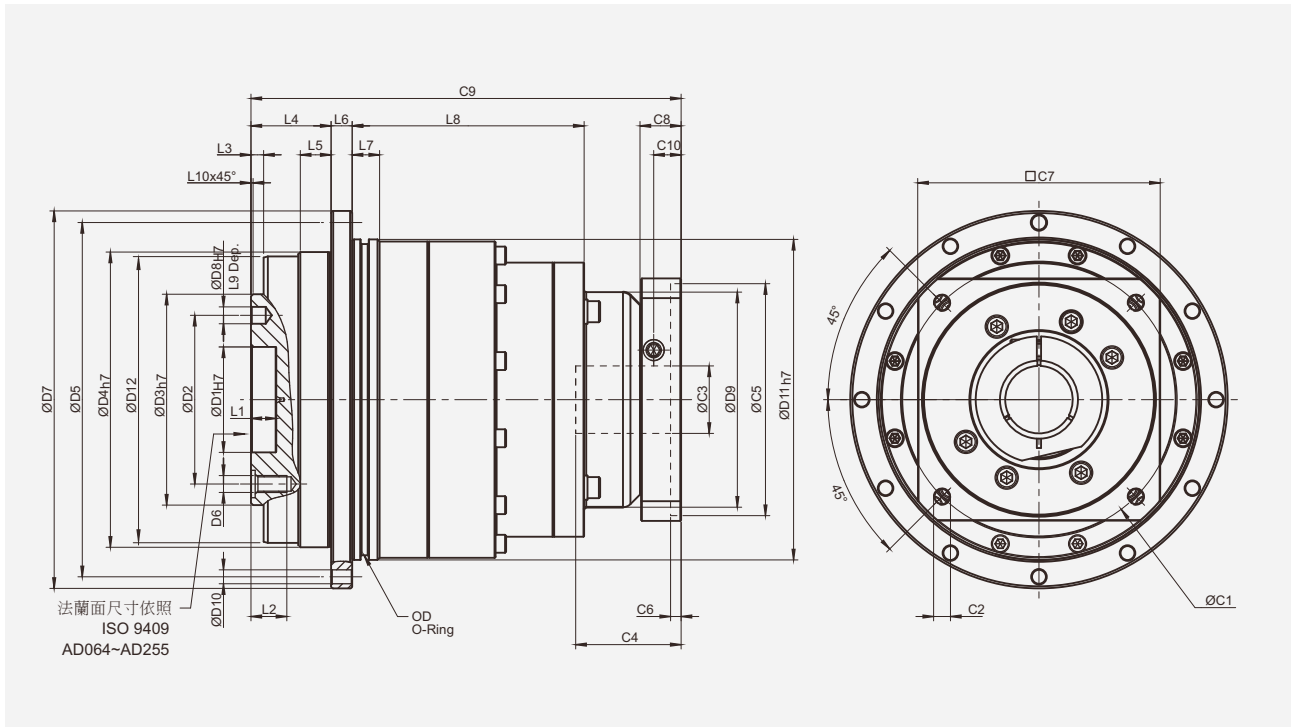

(單位: mm)

尺寸	AD047	AD064	AD090	AD110	AD140	AD200	AD255
D1 _{H7}	12	20	31.5	40	50	80	100
D2	20	31.5	50	63	80	125	140
D3 _{h7}	28	40	63	80	100	160	180
D4 _{h7}	47	64	90	110	140	200	255
D5	67	79	109	135	168	233	280
D6	4 x M3 x 0.5P	7 x M5 x 0.8P	7 x M6 x 1P	11 x M6 x 1P	11 x M8 x 1.25P	11 x M10 x 1.5P	12 x M16 x 2P
D7	72	86	118	145	179	247	300
D8 _{H7}	3	5	6	6	8	10	12
D9	45.5	45.5	53.4	77	102	125	160
D10	8 x 3.4	8 x 4.5	8 x 5.5	8 x 5.5	12 x 6.6	12 x 9	16 x 13.5
D11 _{h7}	60	70	95	120	152	212	255
D12	46.2	63.2	89.2	109.2	139.2	199.2	254.2
L1	4	8	12	12	12	16	20
L2	6.5	8	13.5	13.5	17	22.5	30.5
L3	3	3	6	6	6	8	12
L4	19.5	19.5	30	29	38	50	66
L5	7	7	10	10	14.6	15	20
L6	4	4	7	8	10	12	18
L7	5	7.7	8	10	12	15	20
L8	54.5	65	60	87.5	110	132.5	148
L9	4	6	7	7	7	10	10
L10	0.5	0.5	1	1	1	1	1
C1 ³	46	46	70	100	130	165	215
C2 ³	M4 x 0.7P	M4 x 0.7P	M5 x 0.8P	M6 x 1P	M8 x 1.25P	M10 x 1.5P	M12 x 1.75P
C3 ³	≤ 11 / ≤ 12	≤ 11 / ≤ 12	≤ 14 / ≤ 15.875 / ≤ 16	≤ 19 / ≤ 24	≤ 32	≤ 38	≤ 48
C4 ³	30	30	34	40	50	60	85
C5 ³	30	30	50	80	110	130	180
C6 ³	3.5	3.5	8	4	5	6	6
C7 ³	48	48	60	90	115	142	190
C8 ³	19.5	19.5	19	17	19.5	22.5	29
C9 ³	97.5	108	134	160	204	248	311.5
C10 ³	13.25	13.25	13.5	10.75	13	15	20.75
OD	56 x 2	66 x 2	90 x 3	110 x 3	145 x 3	200 x 5	238 x 5

3. C1~C10 是公制標準馬達連接板之尺寸, 請上網點選“減速機選用”找出正確之尺寸。

AD 系列

尺寸 (雙節, 減速比 $i = 16, 21, 31, 61, 91$)

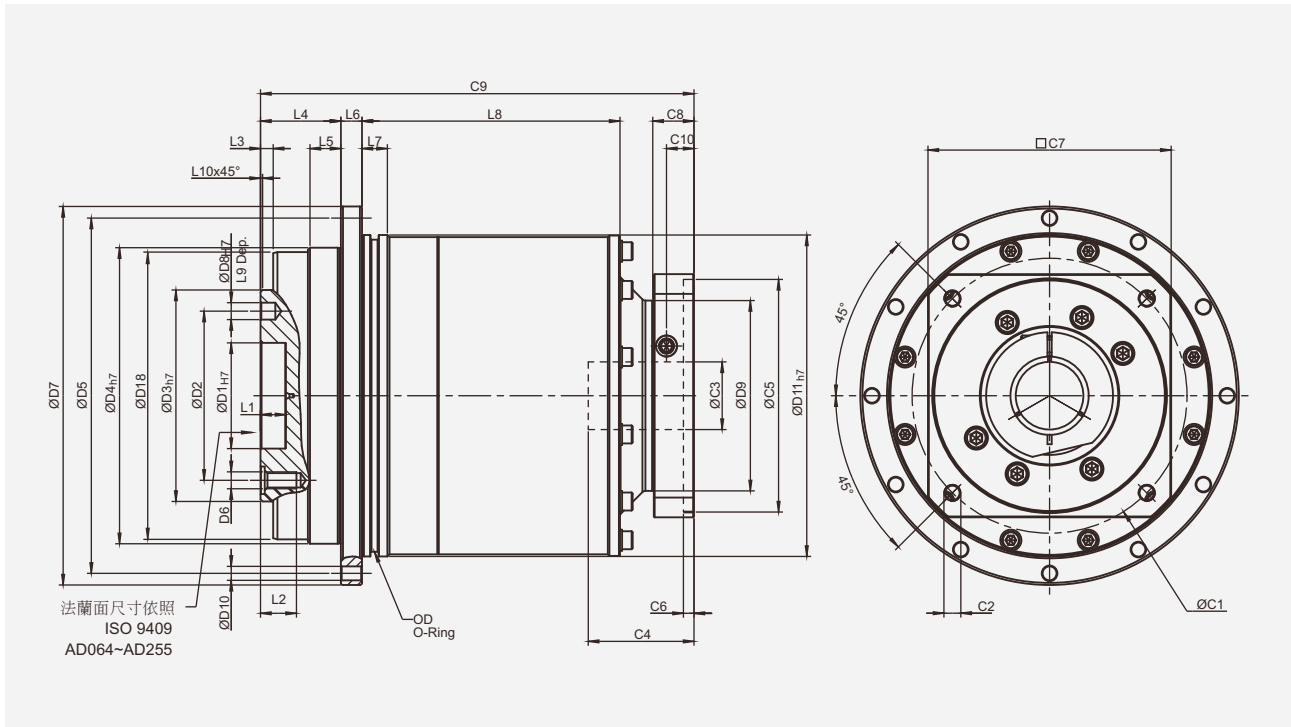

(單位: mm)

尺寸	AD047	AD064	AD090	AD110	AD140	AD200	AD255
D1 _{H7}	12	20	31.5	40	50	80	100
D2	20	31.5	50	63	80	125	140
D3 _{h7}	28	40	63	80	100	160	180
D4 _{h7}	47	64	90	110	140	200	255
D5	67	79	109	135	168	233	280
D6	4 x M3 x 0.5P	7 x M5 x 0.8P	7 x M6 x 1P	11 x M6 x 1P	11 x M8 x 1.25P	11 x M10 x 1.5P	12 x M16 x 2P
D7	72	86	118	145	179	247	300
D8 _{H7}	3	5	6	6	8	10	12
D9	45.5	45.5	55	77	90	113	138
D10	8 x 3.4	8 x 4.5	8 x 5.5	8 x 5.5	12 x 6.6	12 x 9	16 x 13.5
D11 _{h7}	60	70	95	120	152	212	255
D18	46.2	63.2	89.2	109.2	139.2	199.2	254.2
L1	4	8	12	12	12	16	20
L2	6.5	8	13.5	13.5	17	22.5	30.5
L3	3	3	6	6	6	8	12
L4	19.5	19.5	30	29	38	50	66
L5	7	7	10	10	14.6	15	20
L6	4	4	7	8	10	12	18
L7	5	7.7	8	10	12	15	20
L8	52.5	28.5	32	37	122	79.5	82
L9	4	6	7	7	7	10	10
L10	0.5	0.5	1	1	1	1	1
C1 ⁴	46	46	70	100	130	165	215
C2 ⁴	M4 x 0.7P	M4 x 0.7P	M5 x 0.8P	M6 x 1P	M8 x 1.25P	M10 x 1.5P	M12 x 1.75P
C3 ⁴	≤ 11 / ≤ 12	≤ 11 / ≤ 12	≤ 14 / ≤ 15.875 / ≤ 16	≤ 19 / ≤ 24	≤ 32	≤ 38	≤ 48
C4 ⁴	30	30	34	40	50	60	85
C5 ⁴	30	30	50	80	110	130	180
C6 ⁴	3.5	3.5	8	4	5	6	6
C7 ⁴	48	48	60	90	115	142	190
C8 ⁴	19.5	19.5	19	17	19.5	22.5	29
C9 ⁴	100	106	130.5	149	205	247.5	323
C10 ⁴	13.25	13.25	13.5	10.75	13	15	20.75
OD	56 x 2	66 x 2	90 x 3	110 x 3	145 x 3	200 x 5	238 x 5

4. C1~C10 是公制標準馬達連接板之尺寸, 請上網點選「減速機選用」找出正確之尺寸。

減速機性能資料

規格	節數	減速比	ADR047	ADR064	ADR090	ADR110	ADR140	ADR200	ADR255	
額定輸出力矩 T_{2N}	1	4	19	48	130	270	560	1,100	1,700	
		5	22	60	160	330	650	1,200	2,000	
		7	19	50	140	300	550	1,100	1,800	
		10	14	60	150	325	650	1,200	2,000	
		14	-	42	140	300	550	1,100	1,800	
		20	-	40	100	230	450	900	1,500	
	2	20	19	-	-	-	-	-	-	-
		25	22	60	160	330	650	1,200	2,000	
		35	19	50	140	300	550	1,100	1,800	
		40	19	48	130	270	560	1,100	1,700	
		50	22	60	160	330	650	1,200	2,000	
		70	19	50	140	300	550	1,100	1,800	
		100	14	40	100	230	450	900	1,500	
		140	-	-	140	300	550	1,100	1,800	
200	-	-	100	230	450	900	1,500			
急停扭矩 T_{2NOT}^B	Nm	1,2	3 倍額定輸出力矩							
額定輸入轉速 n_{1N}	rpm	1,2	5,000	5,000	4,000	4,000	3,000	3,000	2,000	
最大輸入轉速 n_{1B}	rpm	1,2	4~200	10,000	10,000	8,000	8,000	6,000	6,000	4,000
超精密背隙 P_0	arcmin	1	4~20	-	-	≤2	≤2	≤2	≤2	≤2
		2	25~200	-	-	≤4	≤4	≤4	≤4	≤4
精密背隙 P_1	arcmin	1	4~20	≤4	≤4	≤4	≤4	≤4	≤4	≤4
		2	25~200	≤7	≤7	≤7	≤7	≤7	≤7	≤7
標準背隙 P_2	arcmin	1	4~20	≤6	≤6	≤6	≤6	≤6	≤6	≤6
		2	25~200	≤9	≤9	≤9	≤9	≤9	≤9	≤9
扭轉剛性	Nm/arcmin	1,2	4~200	7	13	31	82	151	440	1,006
最大彎曲力矩 M_{2KB}^C	Nm	1,2	4~200	42.5	125	235	430	1,300	3,064	5,900
容許軸向力 F_{2aB}^C	N	1,2	4~200	990	1,050	2,850	2,990	10,590	16,660	29,430
使用壽命 ^D	hr	1,2	4~200	30,000						
效率 η	%	1	4~20	≥95%						
		2	25~200	≥92%						
重量	kg	1	4~20	1.1	2.1	5.9	10.5	21.9	50.9	85.4
		2	25~200	1.4	1.9	4.5	9.8	20.1	45.4	85.9
使用溫度	°C	1,2	4~200	-10°C~90°C						
潤滑				合成潤滑油脂						
防護等級		1,2	4~200	IP65						
安裝方向		1,2	4~200	任意方向						
噪音值 ($n=3000\text{rpm}$, $i=10$, 無負載) ^E	dB(A)	1,2	4~200	≤61	≤63	≤65	≤68	≤70	≤72	≤74

減速機轉動慣量

規格	節數	減速比	ADR047	ADR064	ADR090	ADR110	ADR140	ADR200	ADR255
轉動慣量 J_1	1	4~10	0.09	0.35	2.25	6.84	23.4	68.9	135.4
		14	-	0.07	1.87	6.25	21.8	65.6	119.8
		20	-	0.07	1.87	6.25	21.8	65.6	119.8
	2	20	0.09	-	-	-	-	-	-
		25~100	0.09	0.09	0.35	2.25	6.84	23.4	68.9
		140~200	-	-	0.31	1.87	6.25	21.8	65.6

A. 減速比 ($i=N_n/N_{out}$)

B. 最大加速力矩 $T_{2B} = 60\%$ of T_{2NOT}

C. 輸出轉數 100 rpm 時，作用於輸出軸中心位置。

D. 連續運轉，使用壽命為 10,000 hrs (請洽詢本公司)

E. 噪音值會隨著減速機比數不同而異

ADR 系列

尺寸 (單節, 減速比 $i = 4 \sim 20$)

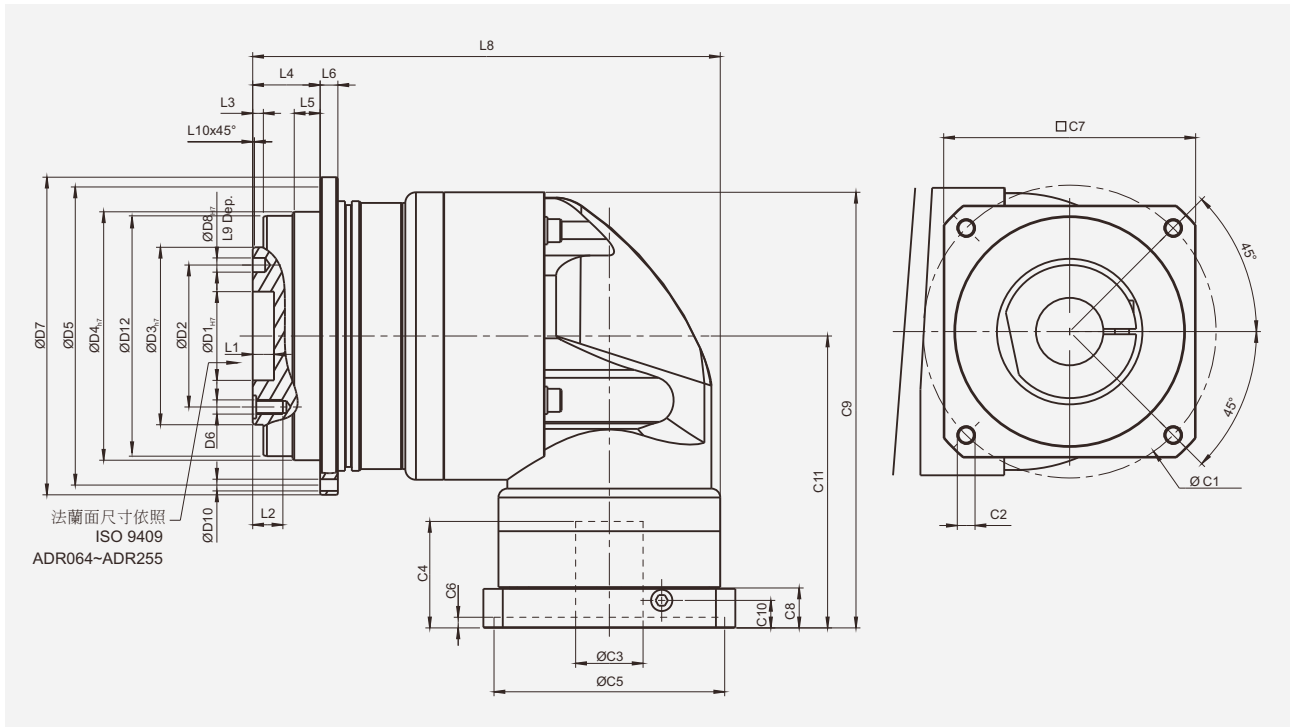

(單位: mm)

尺寸	ADR047	ADR064	ADR090	ADR110	ADR140	ADR200	ADR255
D1 _{H7}	12	20	31.5	40	50	80	100
D2	20	31.5	50	63	80	125	140
D3 _{h7}	28	40	63	80	100	160	180
D4 _{h7}	47	64	90	110	140	200	255
D5	67	79	109	135	168	233	280
D6	4 x M3 x 0.5P	7 x M5 x 0.8P	7 x M6 x 1P	11 x M6 x 1P	11 x M8 x 1.25P	11 x M10 x 1.5P	12 x M16 x 2P
D7	72	86	118	145	179	247	300
D8 _{H7}	3	5	6	6	8	10	12
D10	8 x 3.4	8 x 4.5	8 x 5.5	8 x 5.5	12 x 6.6	12 x 9	16 x 13.5
D12	46.2	63.2	89.2	109.2	139.2	199.2	254.2
L1	4	8	12	12	12	16	20
L2	6.5	8	13.5	13.5	17	22.5	30.5
L3	3	3	6	6	6	8	12
L4	19.5	19.5	30	29	38	50	66
L5	7	7	10	10	14.6	15	20
L6	4	4	7	8	10	12	18
L8	107.5	126	172.5	201	263.5	334.5	392
L9	4	6	7	7	7	10	10
L10	0.5	0.5	1	1	1	1	1
C1 ¹	46	70	100	130	165	215	235
C2 ¹	M4 x 0.7P	M5 x 0.8P	M6 x 1P	M8 x 1.25P	M10 x 1.5P	M12 x 1.75P	M12 x 1.75P
C3 ¹	≤ 11 / ≤ 12	≤ 14 / ≤ 16	≤ 19 / ≤ 24	≤ 32	≤ 38	≤ 48	≤ 55
C4 ¹	30	34	40	50	60	85	116
C5 ¹	30	50	80	110	130	180	200
C6 ¹	3.5	8	4	5	6	6	6
C7 ¹	48	60	90	115	142	190	220
C8 ¹	19.5	19	17	19.5	22.5	29	63
C9 ¹	104.25	116.5	159.5	199	245.5	316	398.5
C10 ¹	13.25	13.5	10.75	13	15	20.75	53.5
C11 ¹	74	81.5	107.5	134	164.5	213.5	268.5

1. C1~C11 是公制標準馬達連接板之尺寸, 請上網點選「減速機選用」找出正確之尺寸。

尺寸 (雙節, 減速比 $i = 25 \sim 200$)

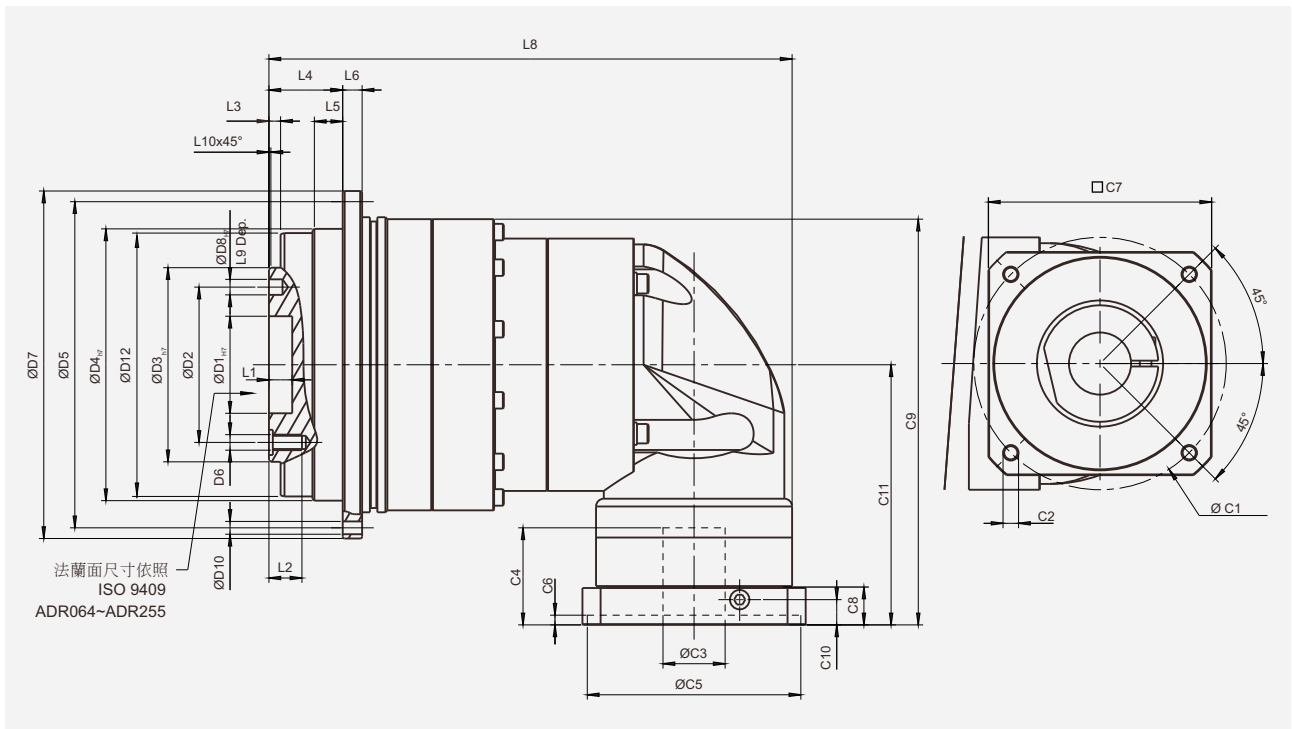

(單位: mm)

尺寸	ADR047	ADR064	ADR090	ADR110	ADR140	ADR200	ADR255
D1 ^{H7}	12	20	31.5	40	50	80	100
D2	20	31.5	50	63	80	125	140
D3 ^{h7}	28	40	63	80	100	160	180
D4 ^{h7}	47	64	90	110	140	200	255
D5	67	79	109	135	168	233	280
D6	4 x M3 x 0.5P	7 x M5 x 0.8P	7 x M6 x 1P	11 x M6 x 1P	11 x M8 x 1.25P	11 x M10 x 1.5P	12 x M16 x 2P
D7	72	86	118	145	179	247	300
D8 ^{H7}	3	5	6	6	8	10	12
D10	8 x 3.4	8 x 4.5	8 x 5.5	8 x 5.5	12 x 6.6	12 x 9	16 x 13.5
D12	46.2	63.2	89.2	109.2	139.2	199.2	254.2
L1	4	8	12	12	12	16	20
L2	6.5	8	13.5	13.5	17	22.5	30.5
L3	3	3	6	6	6	8	12
L4	19.5	19.5	30	29	38	50	66
L5	7	7	10	10	14.6	15	20
L6	4	4	7	8	10	12	18
L8	122	132.5	163	217.5	269.5	333.5	403
L9	4	6	7	7	7	10	10
L10	0.5	0.5	1	1	1	1	1
C1 ²	46	46	70	100	130	165	215
C2 ²	M4 x 0.7P	M4 x 0.7P	M5 x 0.8P	M6 x 1P	M8 x 1.25P	M10 x 1.5P	M12 x 1.75P
C3 ²	≤11 / ≤12	≤11 / ≤12	≤14 / ≤15.875 / ≤16	≤19 / ≤24	≤32	≤38	≤48
C4 ²	30	30	34	40	50	60	85
C5 ²	30	30	50	80	110	130	180
C6 ²	3.5	3.5	8	4	5	6	6
C7 ²	48	48	60	90	115	142	190
C8 ²	19.5	19.5	19	17	19.5	22.5	29
C9 ²	103.25	108.25	128.25	166.5	209	269.5	340
C10 ²	13.25	13.25	13.5	10.75	13	15	20.75
C11 ²	74	74	81.5	107.5	134	164.5	213.5

2. C1~C11 是公制標準馬達連接板之尺寸, 請上網點選“減速機選用”找出正確之尺寸。

ADS 系列

產品規格

減速機性能資料

規格	節數	減速比	ADS047	ADS064	ADS090	ADS110	ADS140	ADS200	ADS255	
額定輸出力矩 T_{2N}	Nm	1	4	19	48	130	270	560	1,100	1,700
			5	22	60	160	330	650	1,200	2,000
			7	19	50	140	300	550	1,100	1,800
			10	14	40	100	230	450	900	1,500
	Nm	2	16	19	48	130	270	560	1,100	1,700
			21	22	60	160	330	650	1,200	2,000
			31	19	50	140	300	550	1,100	1,800
			61	19	50	140	300	550	1,100	1,800
		91	14	40	100	230	450	900	1,500	
急停扭矩 T_{2NOT}^2	Nm	1,2	4~91	3 倍額定輸出力矩						
額定輸入轉速 n_{1N}	rpm	1,2	4~91	5,000	5,000	4,000	4,000	3,000	3,000	2,000
最大輸入轉速 n_{1B}	rpm	1,2	4~91	10,000	10,000	8,000	7,500	4,500	4,500	3,800
超精密背隙 $P0$	arcmin	1	4~10	-	-	≤1	≤1	≤1	≤1	≤1
		2	16~91	-	-	-	≤3	≤3	≤3	≤3
精密背隙 $P1$	arcmin	1	4~10	≤3	≤3	≤3	≤3	≤3	≤3	≤3
		2	16~91	≤5	≤5	≤5	≤5	≤5	≤5	≤5
標準背隙 $P2$	arcmin	1	4~10	≤5	≤5	≤5	≤5	≤5	≤5	≤5
		2	16~91	≤7	≤7	≤7	≤7	≤7	≤7	≤7
扭轉剛性	Nm/arcmin	1,2	4~91	3	7	14	25	50	145	225
最大彎曲力矩 M_{2KB}^C	Nm	1,2	4~91	42.5	125	235	430	1,300	3,064	5,900
最大軸向力	N	1,2	4~91	990	1,050	2,850	2,990	10,590	16,660	29,430
輸入端容許徑向力 F_{1rB}^C	N	1	4~10	165	395	1,300	1,525	2,800	4,500	12,500
		2	16~91	165	165	395	1,300	1,525	2,800	4,500
輸入端容許軸向力 F_{1ab}^C	N	1	4~10	580	1,000	1,100	980	2,700	4,700	8,000
		2	16~91	580	580	1,000	1,100	980	2,700	4,700
使用壽命 ^D	hr	1,2	4~91	30,000						
效率 η	%	1	4~10	≥97%						
		2	16~91	≥94%						
重量	kg	1	4~10	0.8	1.4	3.4	6.7	13.5	35.0	63.8
		2	16~91	1.1	1.6	4.0	7.3	16.6	36.4	74.7
使用溫度	°C	1,2	4~91	-10°C~90°C						
潤滑				合成潤滑油脂						
防護等級		1,2	4~91	IP65						
安裝方向		1,2	4~91	任意方向						
噪音值 ($n=3000\text{rpm}$, $i=10$, 無負載) ^E	dB(A)	1,2	4~91	≤56	≤58	≤60	≤63	≤65	≤67	≤70

減速機轉動慣量

規格	節數	減速比	ADS047	ADS064	ADS090	ADS110	ADS140	ADS200	ADS255	
轉動慣量 J_1	kg · cm ²	1	4	0.06	0.21	0.87	3.65	10.27	43.05	102.68
			5	0.06	0.21	0.83	3.53	10.17	41.76	99.12
			7	0.06	0.21	0.82	3.47	9.99	41.15	97.41
			10	0.06	0.21	0.81	3.45	9.93	40.97	97.03
	kg · cm ²	2	16	0.06	0.06	0.21	0.83	3.53	10.17	41.76
			21	0.06	0.06	0.21	0.83	3.53	10.17	41.76
			31	0.06	0.06	0.21	0.83	3.53	10.17	41.76
			61	0.06	0.06	0.21	0.81	3.45	9.93	40.97
			91	0.06	0.06	0.21	0.81	3.45	9.93	40.97

A. 減速比 ($i=N_n/N_{out}$)

B. 最大加速力矩 $T_{2B} = 60\%$ of T_{2NOT}

C. 輸出轉數 100 rpm 時，作用於輸出軸中心位置。

D. 連續運轉，使用壽命為 10,000 hrs (請諮詢本公司)

E. 噪音值會隨著減速機比數不同而異

尺寸 (單節, 減速比 $i = 4 \sim 10$)

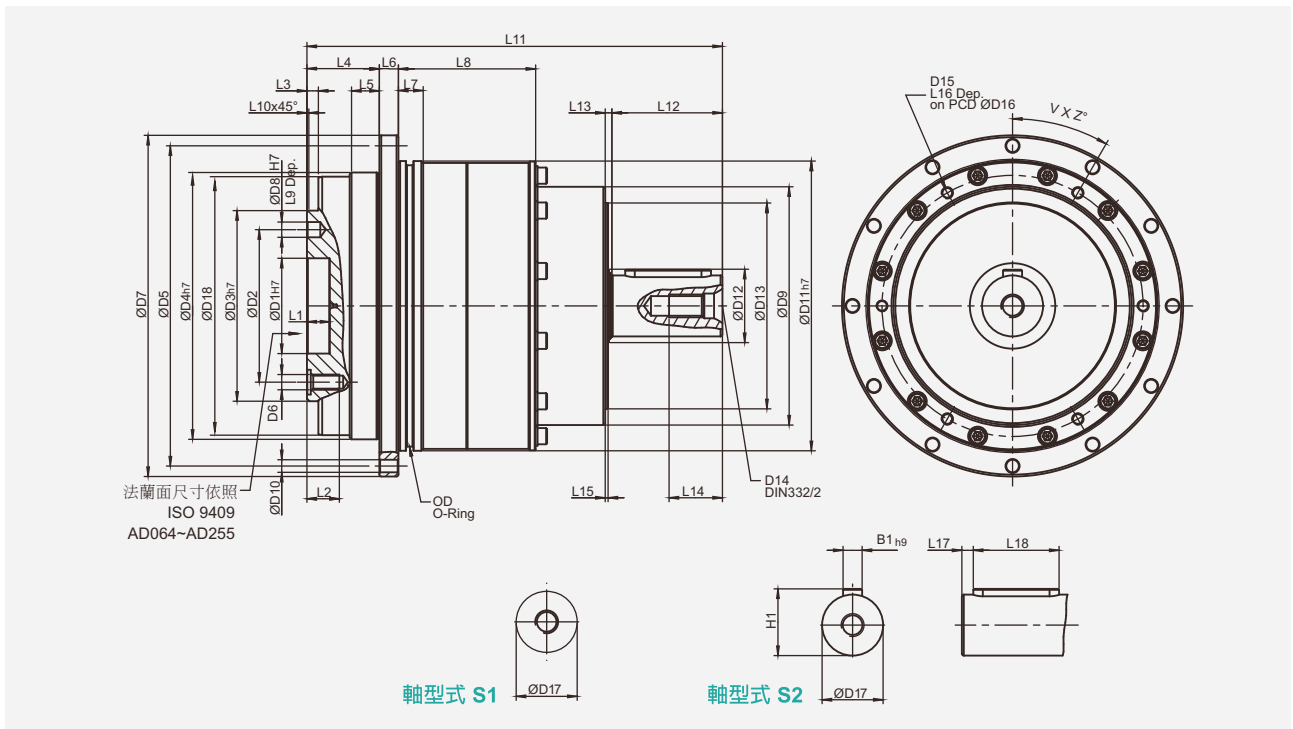

(單位 : mm)

尺寸	ADS047	ADS064	ADS090	ADS110	ADS140	ADS200	ADS255
D1 _{H7}	12	20	31.5	40	50	80	100
D2	20	31.5	50	63	80	125	140
D3 _{H7}	28	40	63	80	100	160	180
D4 _{H7}	47	64	90	110	140	200	255
D5	67	79	109	135	168	233	280
D6	4 x M3 x 0.5P	7 x M5 x 0.8P	7 x M6 x 1P	11 x M6 x 1P	11 x M8 x 1.25P	11 x M10 x 1.5P	12 x M16 x 2P
D7	72	86	118	145	179	247	300
D8 _{H7}	3	5	6	6	8	10	12
D9	43	55	78	100	125	175	210
D10	8 x 3.4	8 x 4.5	8 x 5.5	8 x 5.5	12 x 6.6	12 x 9	16 x 13.5
D11 _{H7}	60	70	95	120	152	212	255
D12	31	22	22	30	40	75	95
D13	37	50	62	82	108	145	172
D14	M4 x 0.7P	M4 x 0.7P	M5 x 0.8P	M8 x 1.25P	M12 x 1.75P	M16 x 2P	M20 x 2.5P
D15	M3 x 0.5P	M3 x 0.5P	M4 x 0.7P	M5 x 0.8P	M6 x 1P	M8 x 1.25P	M8 x 1.25P
D16	51.5	61.5	84	107	137	193	235
D17 _{K6}	11	14	16	22	32	40	55
D18	46.2	63.2	89.2	109.2	139.2	199.2	254.2
L1	4	8	12	12	12	16	20
L2	6.5	8	13.5	13.5	17	22.5	30.5
L3	3	3	6	6	6	8	12
L4	19.5	19.5	30	29	38	50	66
L5	7	7	10	10	14.6	15	20
L6	4	4	7	8	10	12	18
L7	5	7.7	8	10	12	15	20
L8	32.5	43.5	47	62	72	89.5	112
L9	4	6	7	7	7	10	10
L10	0.5	0.5	1	1	1	1	1
L11	89.5	110.5	138.5	170	218	296	372.5
L12	18	22	28	36	58	82	115
L13	2.5	2.5	3.5	3.5	3.5	4.5	4.5
L14	10	10	12.5	19	28	36	42
L15	1.5	1.5	1.5	1.5	1.5	1.5	1.5
L16	5.5	5.5	7	9	11	14	14
L17	2	2	3	3	6	6	7
L18	14	18	22	28	45	70	90
B1 _{H9}	4	5	5	6	10	12	16
H1	12.5	16	18	24.5	35	43	59
OD	56 x 2	66 x 2	90 x 3	110 x 3	145 x 3	200 x 5	238 x 5
V	4	4	4	4	6	6	6
Z	45	45	45	45	30	30	30

ADS 系列

尺寸 (雙節, 減速比 $i = 16, 21, 31, 61, 91$)

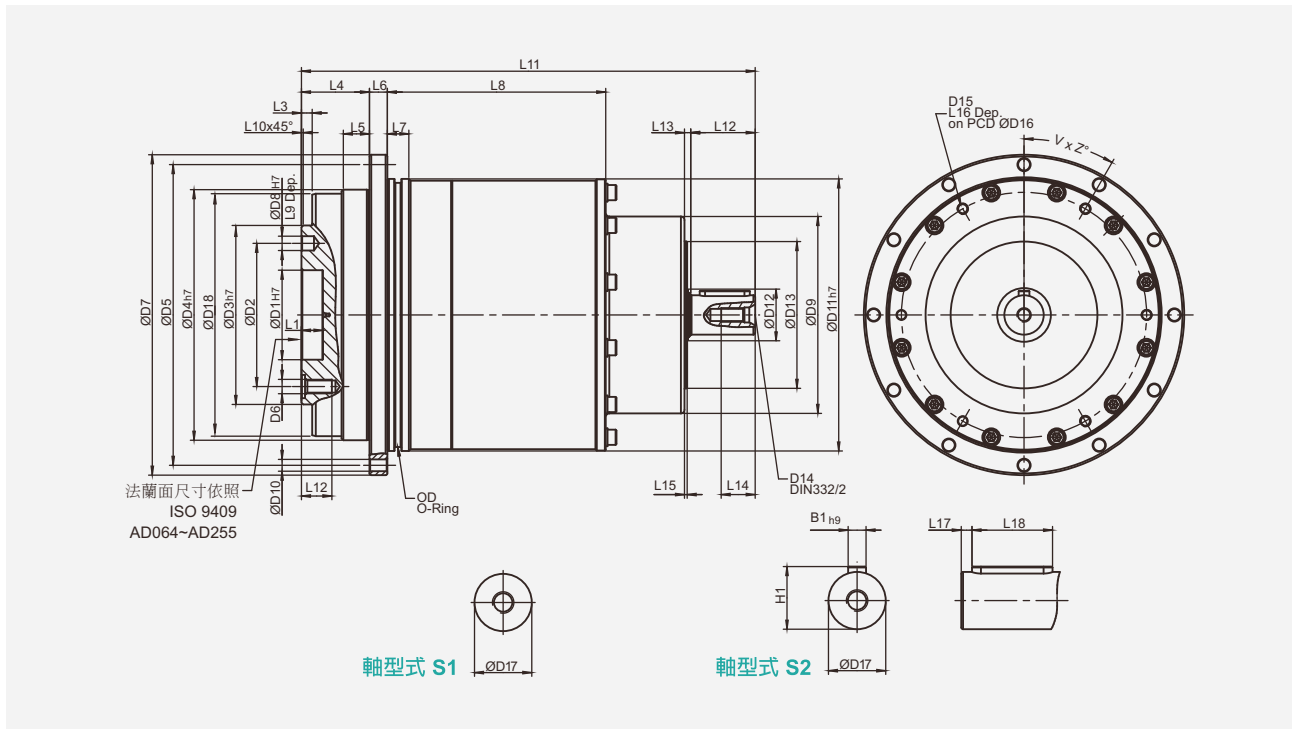

(單位: mm)

尺寸	ADS047	ADS064	ADS090	ADS110	ADS140	ADS200	ADS255
D1 _{H7}	12	20	31.5	40	50	80	100
D2	20	31.5	50	63	80	125	140
D3 _{h7}	28	40	63	80	100	160	180
D4 _{h7}	47	64	90	110	140	200	255
D5	67	79	109	135	168	233	280
D6	4 x M3 x 0.5P	7 x M5 x 0.8P	7 x M6 x 1P	11 x M6 x 1P	11 x M8 x 1.25P	11 x M10 x 1.5P	12 x M16 x 2P
D7	72	86	118	145	179	247	300
D8 _{H7}	3	5	6	6	8	10	12
D9	43	48	68	86	110	132	182
D10	8 x 3.4	8 x 4.5	8 x 5.5	8 x 5.5	12 x 6.6	12 x 9	16 x 13.5
D11 _{h7}	60	70	95	120	152	212	255
D12	22	22	22	22	30	40	75
D13	37	37	50	62	82	108	145
D14	M4 x 0.7P	M4 x 0.7P	M4 x 0.7P	M5 x 0.8P	M8 x 1.25P	M12 x 1.75P	M16 x 2P
D15	M3 x 0.5P	M3 x 0.5P	M4 x 0.7P	M5 x 0.8P	M6 x 1P	M8 x 1.25P	M10 x 1.5P
D16	51.5	61.5	84	107	137	193	235
D17 _{K6}	11	11	14	16	22	32	40
D18	46.2	63.2	89.2	109.2	139.2	199.2	254.2
L1	4	8	12	12	12	16	20
L2	6.5	8	13.5	13.5	17	22.5	30.5
L3	3	3	6	6	6	8	12
L4	19.5	19.5	30	29	38	50	66
L5	7	7	10	10	14.6	15	20
L6	4	4	7	8	10	12	18
L7	5	7.7	8	10	12	15	20
L8	62.5	63.5	67	82	122	79.5	177
L9	4	6	7	7	7	10	10
L10	0.5	0.5	1	1	1	1	1
L11	119.5	125.5	158.5	188	253.5	314.5	419.5
L12	18	18	22	28	36	58	82
L13	2.5	2.5	2.5	3.5	3.5	3.5	4.5
L14	10	10	10	12.5	19	28	36
L15	1.5	1.5	1.5	1.5	1.5	1.5	1.5
L16	5.5	5.5	7	9	11	14	18
L17	2	2	2	3	3	6	6
L18	14	14	18	22	28	45	70
B1 _{h9}	4	4	5	5	6	10	12
H1	12.5	12.5	16	18	24.5	35	43
OD	56 x 2	66 x 2	90 x 3	110 x 3	145 x 3	200 x 5	238 x 5
V	4	4	4	4	6	6	6
Z	45	45	45	45	30	30	30

出力軸尺寸

**AD 047
ADR 047
ADS 047**

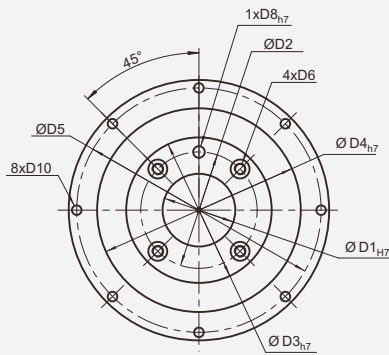

**AD 064 / AD 090
ADR 064 / ADR 090
ADS 064 / ADS 090**

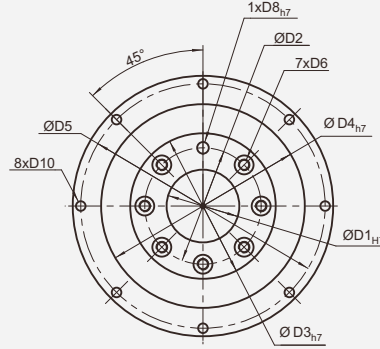

**AD 110
ADR 110
ADS 110**

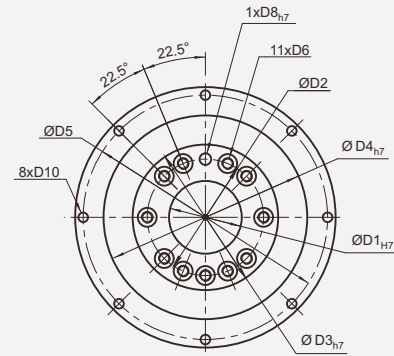

**AD 140 / AD 200
ADR 140 / ADR 200
ADS 140 / ADS 200**

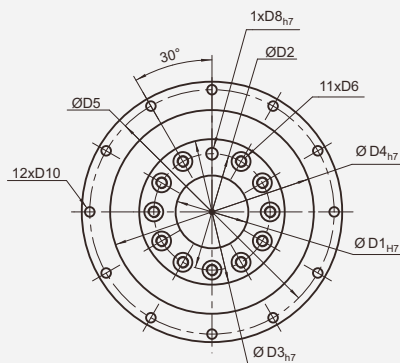

**AD 255
ADR 255
ADS 255**

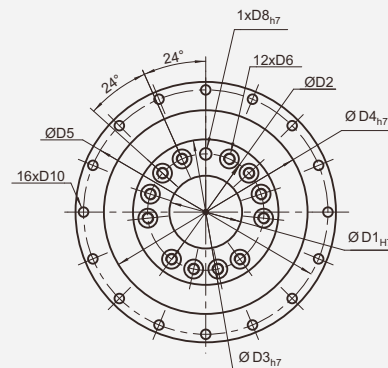

(單位 : mm)

尺寸	AD047	AD064	AD090	AD110	AD140	AD200	AD255
	ADR047	ADR064	ADR090	ADR110	ADR140	ADR200	ADR255
	ADS047	ADS064	ADS090	ADS110	ADS140	ADS200	ADS255
D1 _{H7}	12	20	31.5	40	50	80	100
D2	20	31.5	50	63	80	125	140
D3 _{h7}	28	40	63	80	100	160	180
D4 _{h7}	47	64	90	110	140	200	255
D5	67	79	109	135	168	233	280
D6	M3 x 0.5P	M5 x 0.8P	M6 x 1P	M6 x 1P	M8 x 1.25P	M10 x 1.5P	M16 x 2P
D8 _{H7}	3	5	6	6	8	10	12
D10	3.4	4.5	5.5	5.5	6.6	9	13.5

減速機輸出軸之容許徑向力及軸向力

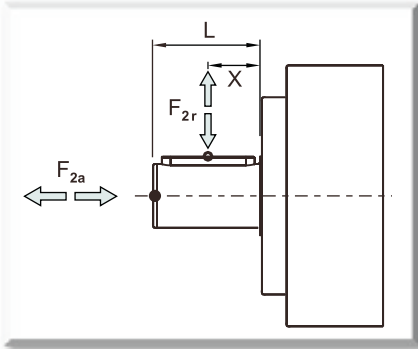

減速機輸出軸所能承受之最大徑向力及軸向力，端視內部支撐軸承之設計，台灣精銳減速機採用大尺寸的軸承及較大跨距的設計，其能承受更大的徑向及軸向負荷。

F_{2r} 徑向力
 F_{2a} 軸向力

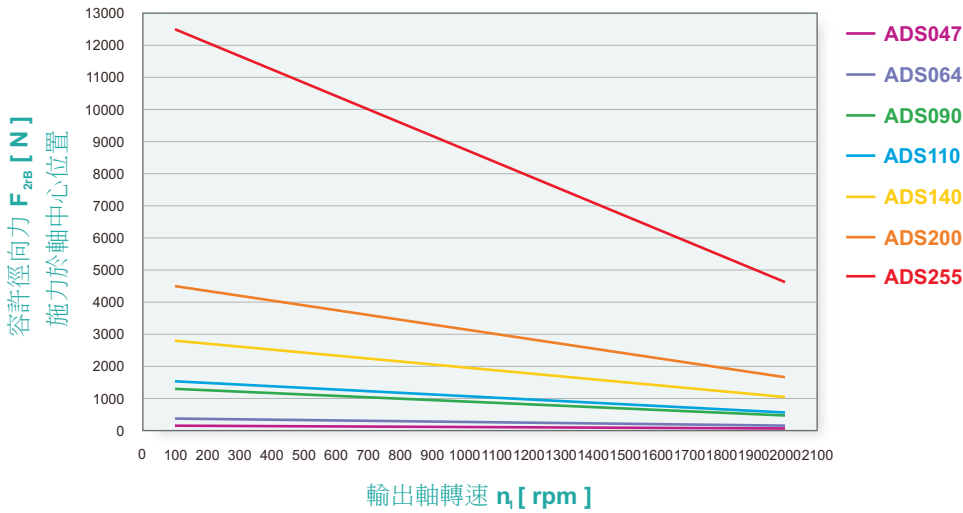

當徑向力 F_{2r} 施力於軸中心位置即 $X=1/2 \times L$ 時，不同規格之減速機在不同輸出轉速運用下，使用壽命為 30,000 hr * 時，所能承受之容許徑向力 F_{2rB} ，請參照左圖。

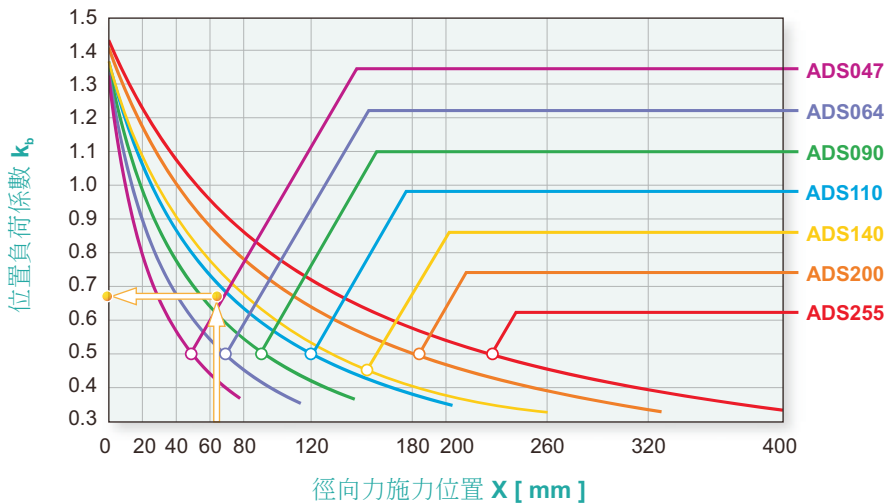

當徑向力 F_{2r} 施力不在軸中心位置時，越靠近減速機即 $X < 1/2 \times L$ ，所能承受之容許徑向力變大，越遠離減速機即 $X > 1/2 \times L$ 時，所能承受之容許徑向力則變小，藉由左圖，依減速機規格及徑向力施力位置 X ，查出位置負荷係數 k_b 。

* 連續運轉降低使用壽命二分之一

減速機訂購

AD 系列

AD047

—

010

—

P1

/

馬達

減速機型式：

AD047, AD064, AD090
AD110, AD140, AD200, AD255

背隙：

P0: 超精密背隙
P1: 精密背隙
P2: 標準背隙

減速比：

單節：4, 5, 7, 10
雙節：20, 25, 35, 40, 50, 70, 100
16, 21, 31, 61, 91

馬達型號：

馬達製造商及型號

選用範例：**AD047-010-P1 / SIEMENS 1FT6 041-4AF71**

ADR 系列

ADR047

—

010

—

P1

/

馬達

減速機型式：

ADR047, ADR064, ADR090
ADR110, ADR140, ADR200, ADR255

背隙：

P0: 超精密背隙
P1: 精密背隙
P2: 標準背隙

減速比：

單節：4, 5, 7, 10, 14, 20
雙節：20, 25, 35, 40, 50, 70, 100, 140, 200

馬達型號：

馬達製造商及型號

Ordering Example: **ADR047-010-P1 / SIEMENS 1FT5 034-OAK71**

ADS 系列

ADS047

—

010

—

S1

—

P1

減速機型式：

ADS047, ADS064, ADS090
ADS110, ADS140, ADS200, ADS255

輸出軸型式選擇：

S1: 平滑直軸
S2: 附鍵直軸

減速比：

單節：4, 5, 7, 10
雙節：16, 21, 31, 61, 91

背隙：

P0: 超精密背隙
P1: 精密背隙
P2: 標準背隙

選用範例：**ADS090-010-S1-P1**

■ 請參照本公司網站之最新產品資訊



APEX DYNAMICS, INC.
台灣精銳科技股份有限公司

407 台中市西屯區科園三路 10 號

電話：04-23550219 / 傳真：04-23550218

電子信箱：sales@apexdyna.com

網站：www.apexdyna.com

